



OPERATORS MANUAL

LOAD KING

16'-18' DUMP BODIES

## Table of Contents

REVISION HISTORY .....	3
INTRODUCTION.....	4
DEFINITIONS USED IN THIS MANUAL.....	5
OPERATORS MANUAL.....	6
1. PRE-USE INSPECTION.....	6
2. PROPER OPERATION SEQUENCE .....	6
2.1) TO DUMP (WITHOUT TAILGATE HIGH LIFT).....	6
2.2) TO DUMP (WITH TAILGATE HIGH LIFT).....	7
2.3) TO LOAD .....	8
3. CAB CONTROLS .....	8
4. POST OPERATION INSPECTION .....	9
SAFETY INFORMATION .....	9
DUMP TRUCK HYDRAULIC DIAGRAM.....	11
DUMP TRUCK AIR PLUMBING SCHEMATIC.....	12
DUMP TRUCK ELECTRICAL SCHEMATIC .....	13
DUMP TRUCK ELECTRICAL WIRING SCHEMATIC.....	14
LUBRICATION AND MAINTENANCE.....	15
LOAD KING DUMP BODY LABELS .....	19
LOAD KING DUMP BODY LABEL LOCATIONS.....	21
LOAD KING WARRANTY .....	22
LIMITATION OF LIABILITY .....	22
LOAD KING WARRANTY DATA RECORD .....	23

**REVISION HISTORY**

<b>NAME</b>	<b>DATE</b>	<b>DESCRIPTION OF CHANGE</b>	<b>REV.</b>
J Haas	7/24/2018	INITIAL RELEASE	A
J Haas	3/6/2019	SCHEMATICS INCULDED (PG. 11-14), HIGH LIFT PIN UPDATE (PG. 15)	B

## Company

Load King has been producing quality trailers since 1956. We are located in Elk Point, South Dakota.

Although the trailer industry is an ever-changing environment and we've seen many changes over the years, we have remained committed to the simple philosophy that we will make a reasonable profit through the designing, manufacturing, and marketing of top quality products that we can always be proud to call Load King. We have not, and will not, compromise in this area.

Quality shows in all facets of an operation, from the moment you make your first phone call for a product inquiry to the time you sell your used equipment and realize you've received top dollar on your sale. We continue to strive for excellence in every area and never quit trying to improve. We have earned our reputation believing that quality is value and value sells products.

Through our shared Engineering, Marketing and Sales teams, Load King and Custom Truck One Source bring that tradition of quality and value to another market with the Load King Dump Body.





## About Custom Truck One Source

Beginning in February of 2015, three family-owned and operated companies (Custom Truck & Equipment, Utility Fleet Sales and Forestry Equipment of VA) joined together to form what is now Custom Truck One Source. Shortly after its inception, UCO Equipment became a part of the CTOS family along with TNT Equipment six months later. In December 2015, CTOS welcomed its sixth company under its brand, Load King, a leading manufacturer of high-quality and customizable trailers.

The announcement of the partnership represented the platform's collective commitment to the continued growth and dominance of each legacy company's individual offerings, now compounded to leverage the expertise of the team and, ultimately, better serve loyal CTOS customers all over the world. CTOS will build upon the market positions of each legacy company, while serving as a single source supplier of specialty equipment and services for the utility and heavy equipment industries. The utility and heavy equipment platform collectively offers sales, rentals, parts and after market services, remanufacturing, customized equipment and transportation.

## DEFINITIONS USED IN THIS MANUAL

The following table describes text and symbols used to highlight important information.

Signal Word	Symbol	Explanation
DANGER		Danger is used to alert readers about an immediate and serious hazard that will likely be fatal.
WARNING		Warning is used to alert readers about the potential for serious injury or death or serious damage to equipment.
CAUTION		Caution is used to alert readers about the potential for anything from moderate injury to serious equipment damage or destruction.
READ		Read is used to alert readers of information to be read on machinery
NOTE		Note is used for a tip or suggestion to help readers carry out a procedure successfully.

Table—1

## OPERATORS MANUAL

---



When using a Load King Dump Body, it is important to have a good understanding of the proper pre-inspection, post-inspections, and operating guidelines. By following these steps, you can safely operate the Load King Dump Body with minimal risks of damage to the machine or the surrounding property.

### 1. PRE-USE INSPECTION:

1. Before using a Load King Dump Body, do a 360 degree walk around to visually inspect that the dump bed will be free of obstructions once in operation.
2. Be sure to check the oil sight gauge on the reservoir to ensure the tank is full and that no oil has leaked out.
3. Visually inspect all critical fasteners to ensure there are no loose or damaged bolts, nuts, or other hardware. Ensure that all lubrication points have been well maintained and lubricated.
4. If any damage to body or hardware is observed, do not operate until a thorough inspection has been conducted and all necessary repairs have been made.

### 2. PROPER OPERATION SEQUENCE:



**DANGER:** Choose an operating location where the bed can be fully raised without approaching power lines or overhead structures, such as tree limbs or light poles.

#### 2.1) To Dump (without tailgate high lift):

1. Position the chassis on level ground, away from potential hazards such as power lines and traffic.
2. Turn on the chassis engine, set the parking brake, and engage the PTO switch located on the center dash panel.
3. If the unit is equipped with a tarper system, always ensure the tarp is fully retracted and stowed before dumping.



4. **WARNING:** When raising a loaded dump body, always release the tailgate pins BEFORE raising the body. The tailgate pins should never be released with a load against the tailgate.



5. **DANGER:** Before operating the dump body, ensure all bystanders are kept well away from the area of operation. Do not allow anyone to stand behind loaded dump body. Do not operate in high traffic areas. Operator must stay at controls through entire dumping process, away from all moving parts, and shielded from road traffic or other potential hazards.
6. Use the "Up" lever to raise dump bed to upright position and dump cargo.

## OPERATORS MANUAL (Cont.)



7. **DANGER:** NEVER place arms, hands, or other body parts under the body while running. NEVER allow anyone under the body while in the raised position without the body securely resting on the body prop. Before lowering the body, ALWAYS ensure no people, animals, tools, or other debris are under the body.
8. Use the “Down” lever to lower body to resting position.
9. Latch tailgate pins.
10. Disengage PTO.

### 2.2) To Dump (with tailgate high lift):

1. Position the chassis on level ground, away from potential hazards such as power lines and traffic.
2. Insert selector pins in the location shown below. (1 each side, 2 total)



**\*NOTE:** Step #2 is only necessary for Dump Body Models equipped with selector pins.



3. Turn on the chassis engine, set the parking brake, and engage the PTO switch located on the center dash panel.
4. If the unit is equipped with a tarp system, always ensure the tarp is fully retracted and stowed before operating high lift system.
5. **DANGER:** Before operating the high lift system, ensure all bystanders are kept well away from the area of operation. Do not allow anyone to stand behind loaded dump body. Do not operate in high traffic areas. Operator must stay at controls through entire tailgate lifting process, away from all moving parts, and shielded from road traffic or other potential hazards.



6. **WARNING:** When using the high lift system, always release the tailgate pins BEFORE raising the tailgate.



## OPERATORS MANUAL (Cont.)

7. Use the "HI-LIFT" switch located on the center dash panel to raise the tailgate.
8. Use the "Up" lever to raise dump bed to upright position and dump cargo.
9. **DANGER:** NEVER place arms, hands, or other body parts under the body while running. NEVER allow anyone under the body while in the raised position without the body securely resting on the body prop. Before lowering the body, ALWAYS ensure no people, animals, tools, or other debris are under the body.
10. Use the "Down" lever to lower body to resting position.
11. Use the "HI-LIFT" switch located on the center dash panel to lower the tailgate.
12. Latch tailgate pins.
13. Disengage PTO.



### 2.3) To Load:

1. **DANGER:** Before loading bed, ensure the bed is in the fully lowered position, the tailgate pins are latched, and all personnel are well clear of the dump bed. UNDER NO CIRCUMSTANCES should anyone be allowed to stand in the dump bed while using powered or gravity fed equipment to load the bed.
2. **CAUTION:** If your dump body is equipped with a tarp system, always fully retract and stow the tarp before loading.



### 3. CAB CONTROLS:



ITEM NO.	DESCRIPTION
1	PTO SWITCH
2	TARP SWITCH
3	HIGH LIFT SWITCH
4	STOBE LIGHT SWITCH
5	TAILGATE LATCH LOCK/RELEASE
6	BED CONTROL LEVER



## OPERATORS MANUAL (Cont.)

### 4. POST OPERATION INSPECTION:

1. Complete a 360 degree walk around to ensure there has been no hydraulic leaks during operation.
2. Visually inspect all critical components and fasteners to ensure they were not damaged or loosened during operations.

### SAFETY INFORMATION



For the operator's protection, there are warning labels and safety devices on the Load King Dump Body that are **NOT** to be tampered with or removed. It is important for the operator to read all warning labels before operating the Load King Dump Body. It is the owner's responsibility to ensure that the operator and workers on and around the Dump Body understand all of the safety warnings herein and affixed to the machine. **Do not operate Dump Body if safety labels are missing or damaged**



1. **WARNING:** Do not modify the hydraulic system in any way. Altering the hydraulic system increases the risk of operator injury and structural harm. Removing, altering or bypassing any hydraulic component directly violates and voids the warranty.



2. **WARNING:** The warning and safety labels must be legible. These labels must not be removed or altered in anyway. These labels are important directions to ensure that neither workers, nor the dump body get damaged during working operations or traveling. The pictures in the following section show the decals and their locations. Operating the unit with illegible or missing safety labels is a direct violation of the intended use of the unit and voids the warranty.



3. **DANGER:** NEVER place arm, hands, or other body parts under the body while running. Never go under a raised body for any reason without the body resting securely on the body prop. Body prop should be checked regularly, and should not be used if damaged. Body prop should be used with empty body only.



4. **DANGER:** Keep all body parts away from moving parts. Do not attempt to manually stop or restrain any moving parts.



5. **DANGER:** This dump body is a piece of heavy machinery and should be treated as such. Do not operate while fatigued, under the influence of any medication which may impair your ability to operate the machinery safely, or while otherwise impaired.



6. **DANGER:** Always be aware of your surroundings when operating dump body. Do not operate in crowded areas, areas of high traffic, or areas with overhead obstacles, especially power lines. Do not allow anyone to stand behind the dump body during operation.

---

**SAFETY INFORMATION (Cont.)**

---



7. **DANGER:** Do not move truck with bed in the upright position, or without the tailgate latched. Doing so could lead to collisions with overhead obstacles or dangerous shifting of loaded materials.



8. **WARNING:** Do not overload. Be mindful of Gross Vehicle Weight Rating of your truck, as well as local laws regarding vehicle weight in your area. Distribute loads evenly in bed to prevent unexpected weight shifts, and be mindful of the effects of increased payload weight on the driving characteristics of your vehicle.



9. **CAUTION:** If your dump body is equipped with a tarp, always fully retract and stow the tarp before loading or unloading. If a tarp is required for your particular load, make sure the load is fully covered before driving.



10. **CAUTION:** Do not drive truck with PTO engaged. This may result in serious damage to chassis and hydraulic systems.

11. Load King is not responsible for any loss or damage resulting from operators neglect of the safety information provided.

# DUMP TRUCK HYDRAULIC DIAGRAM

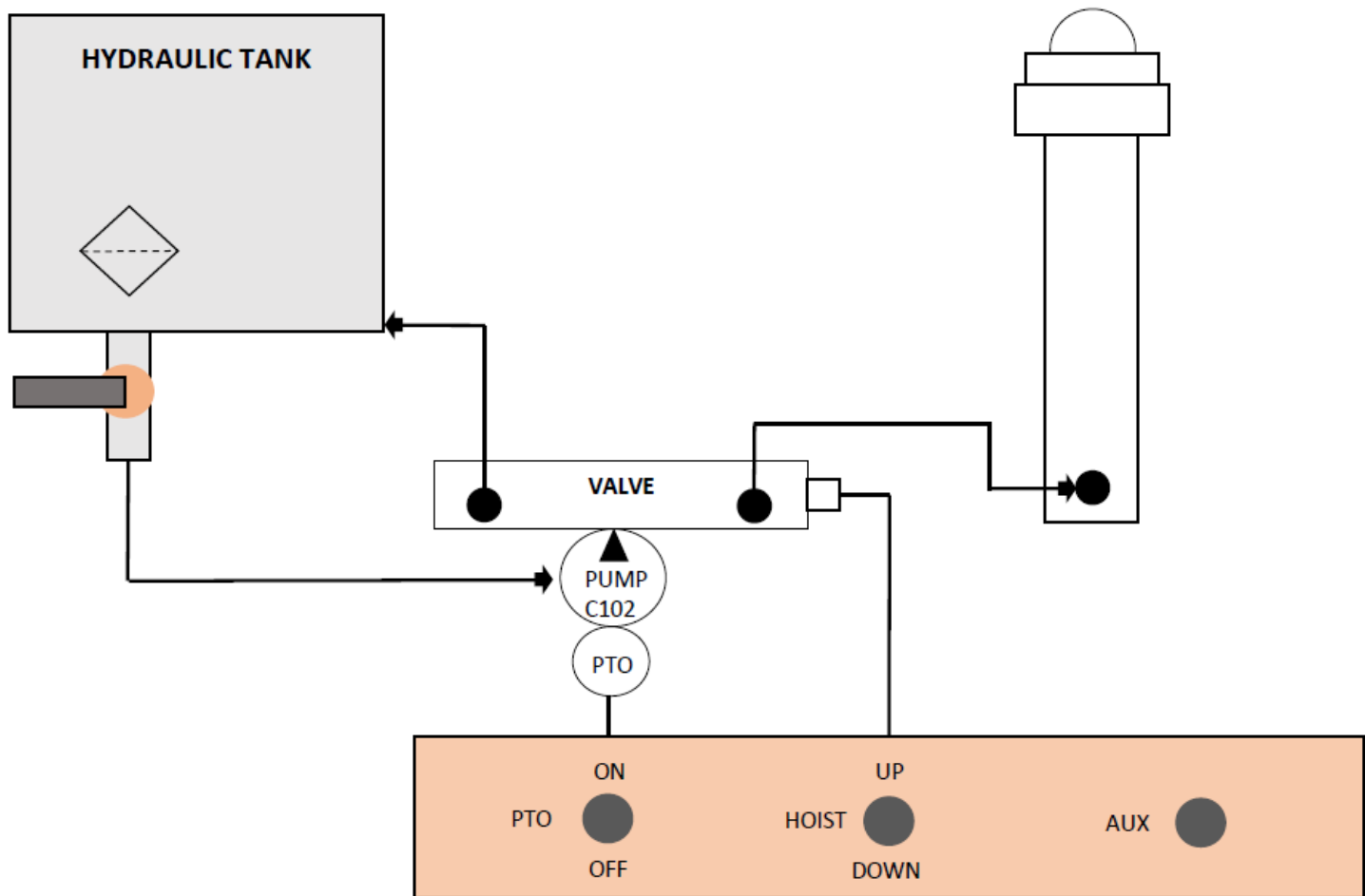

**DUMP TRUCK AIR PLUMBING SCHEMATIC**

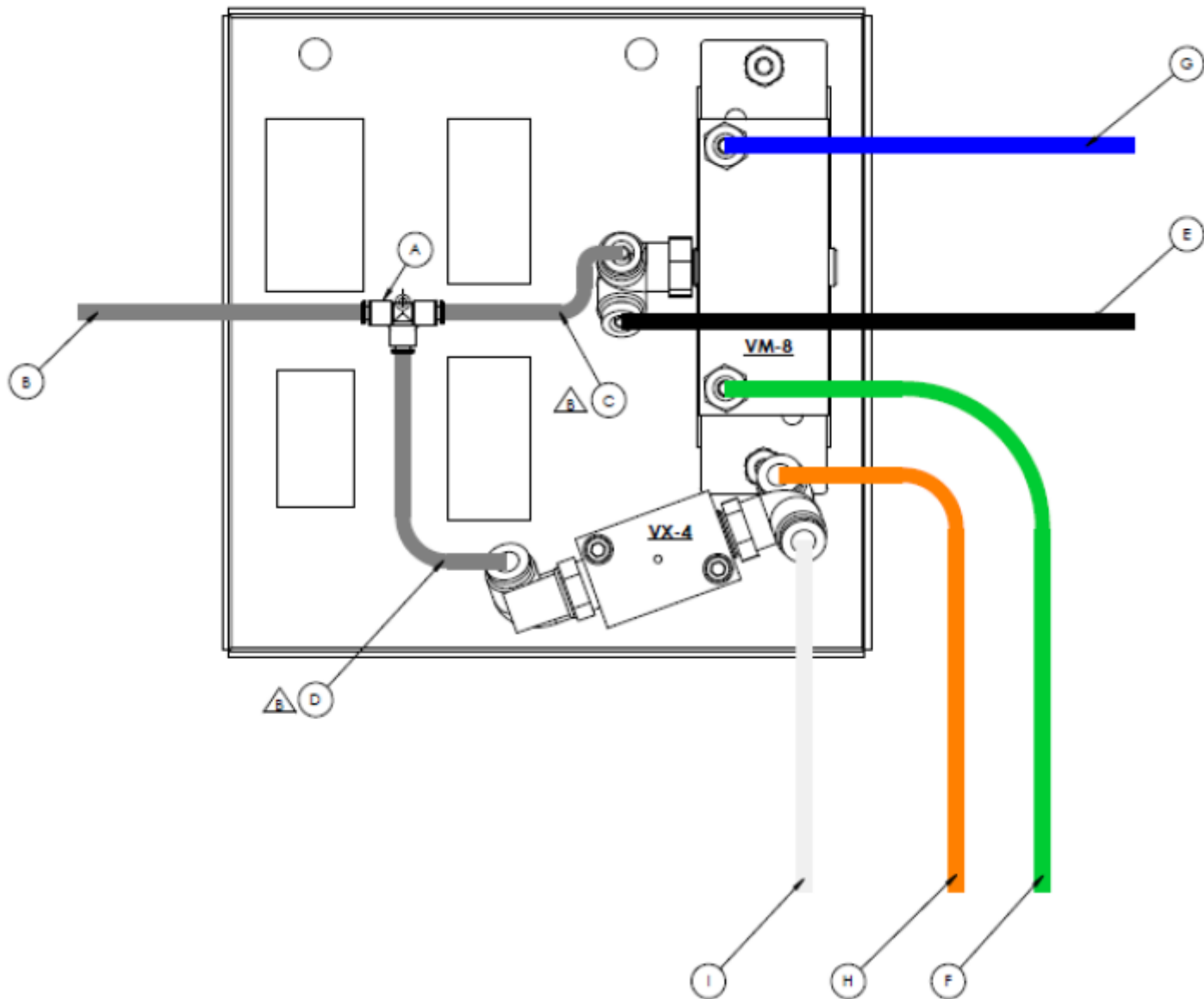

ITEM	LENGTH	DESCRIPTION	TUBE COLOR CODE
A	N/A	TEE UNION 1/4 TUBE	N/A
B	15 ft	TUBE 1/4 DOT SILVER	SUPPLY
C	2 in	TUBE 1/4 DOT SILVER	SUPPLY
D	5 in	TUBE 1/4 DOT SILVER	SUPPLY
E	15 ft	TUBE 1/4 DOT BLACK	EXHAUST
F	15 ft	TUBE 1/4 DOT GREEN	HOIST RAISE
G	15 ft	TUBE 1/4 DOT BLUE	HOIST LOWER
H	15 ft	TUBE 1/4 DOT ORANGE	PUSH TO CLOSE
I	15 ft	TUBE 1/4 DOT WHITE	PUSH TO OPEN

# DUMP TRUCK ELECTRICAL SCHEMATIC

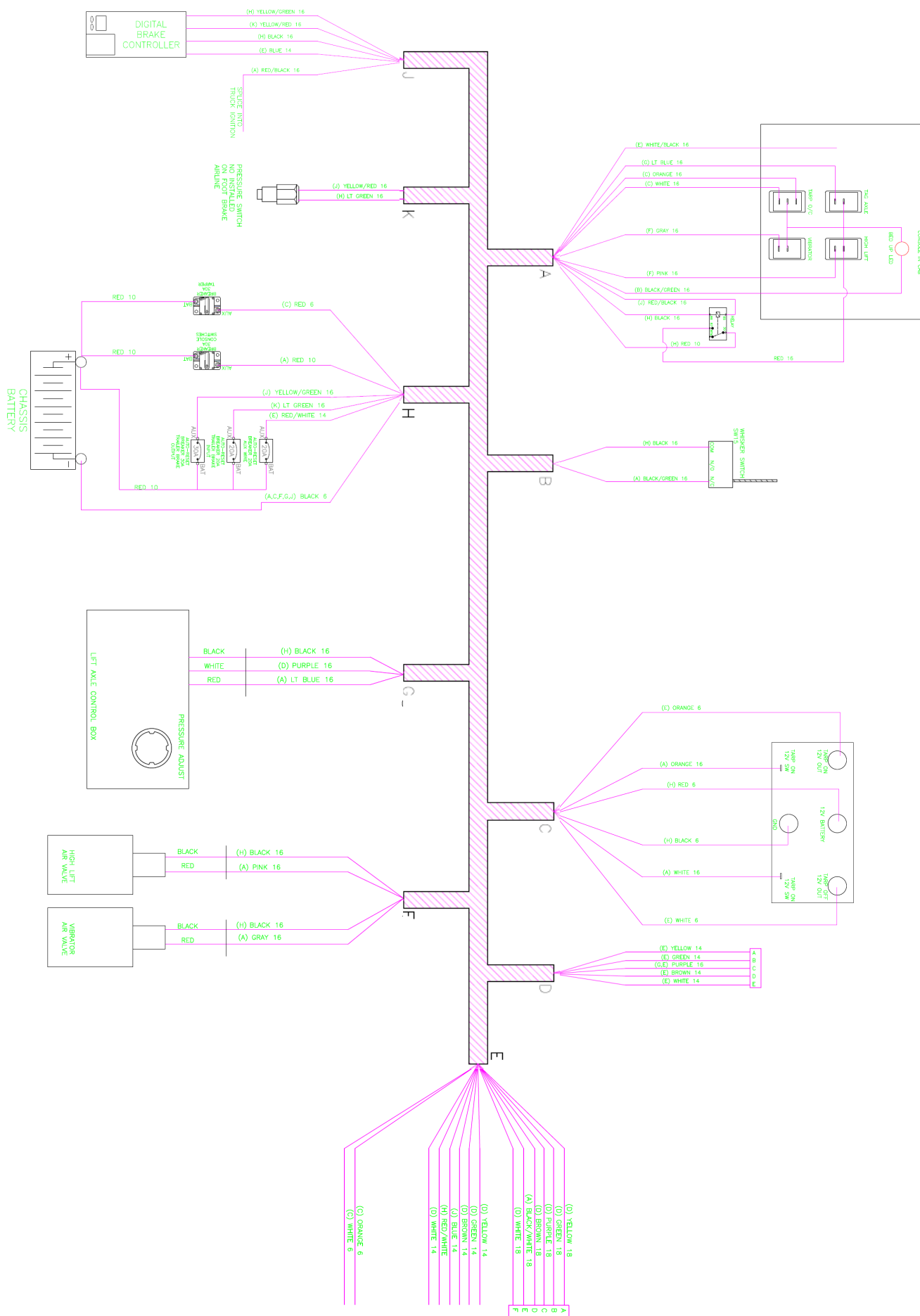

# DUMP TRUCK ELECTRICAL WIRING SCHEMATIC

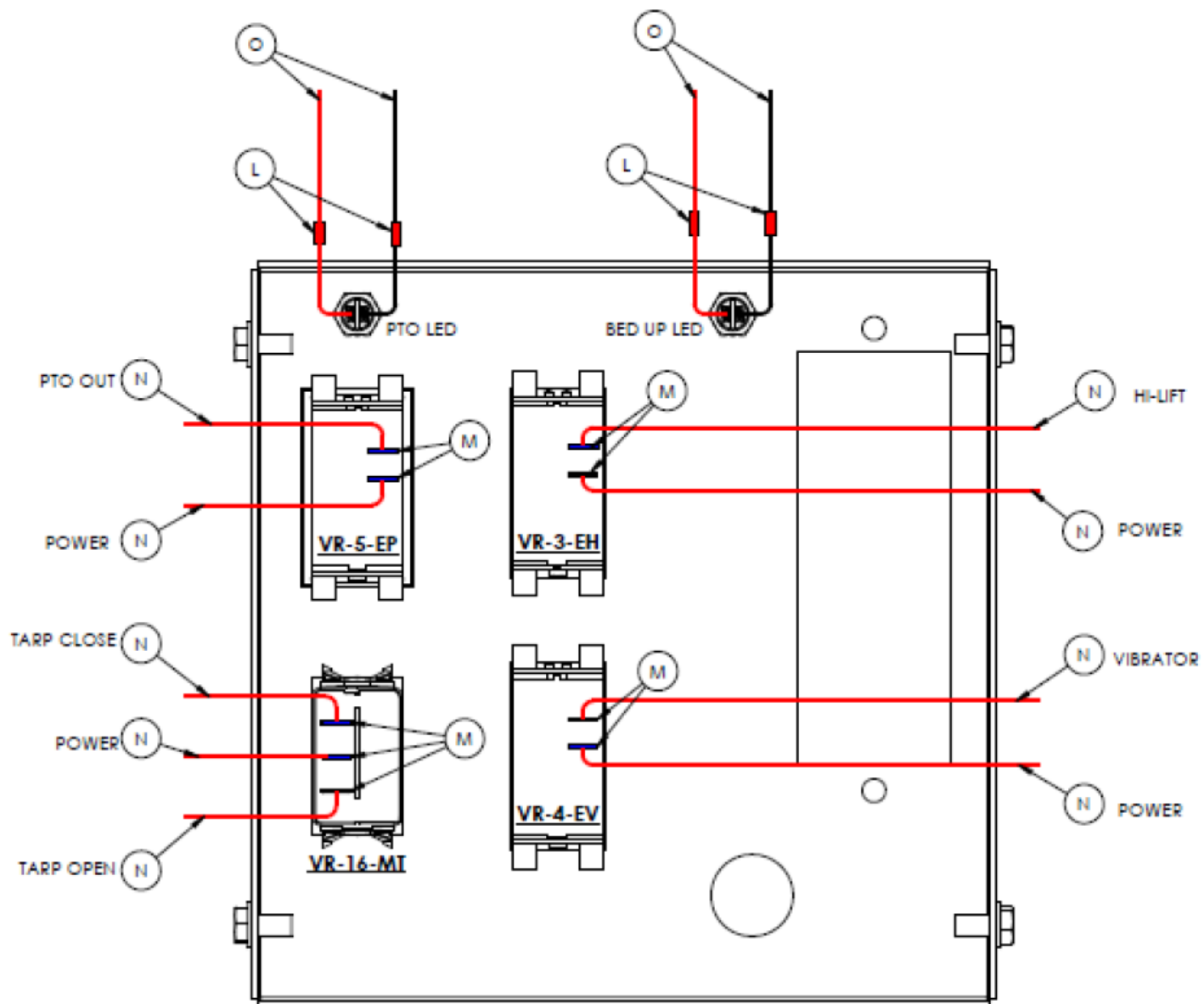

ITEM	LENGTH	DESCRIPTION	QTY.
L	N/A	CONNECTOR 22-18 AWG BUTT RED	4
M	N/A	CONNECTOR 16-14 AWG FEMALE - BL	9
N	15 ft	WIRE 16 AWG RED	9
O	15 ft	WIRE 22 AWG RED/ BLACK PAIR	2

## LUBRICATION AND MAINTENANCE

Lubricate grease zerks in high lift pins and tailgate latch pins. (3 each side, 6 total). *Locations indicated with red arrows below*



If your Load King Dump Body is equipped with pin #DMP00764 in this location, replace with pin #DMP01835 (Both pins shown below).

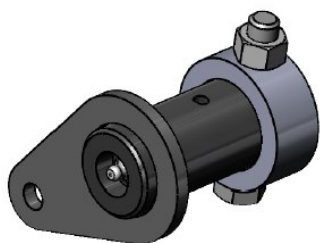

**DMP01835**

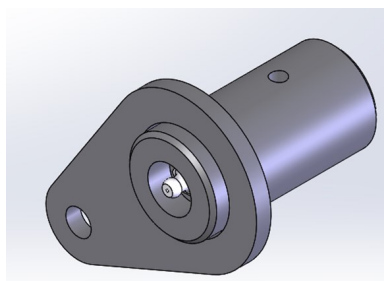

**DMP00764**



**CAUTION:** ALL grease zerks are to be topped off prior to first use and every month following.

**LUBRICATION AND MAINTENANCE (Cont.)**

Lubricate grease zerks in main rear hinge. (6 total). *Locations shown below*

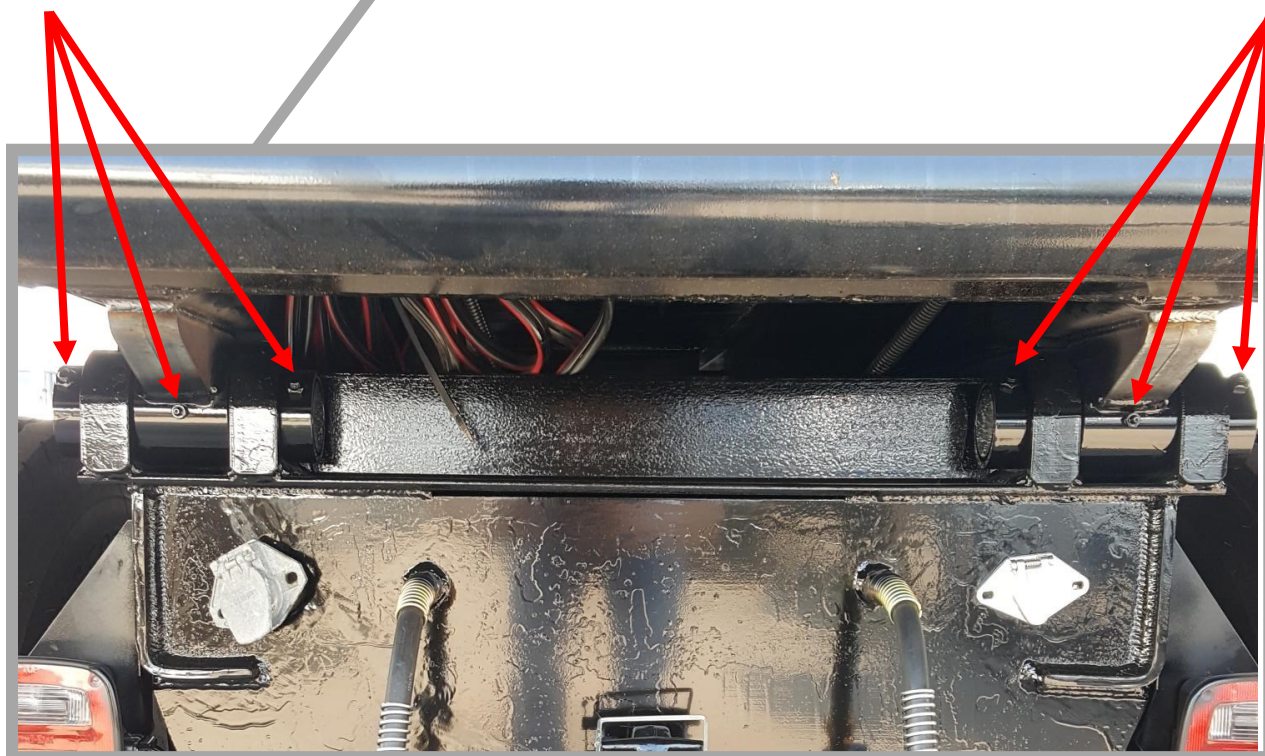

**CAUTION:** ALL grease zerks are to be topped off prior to first use and every month following.



## LUBRICATION AND MAINTENANCE (Cont.)

Lubricate grease zerks in lift cylinder's trunnion pivot points. (4 total). *Locations shown below*

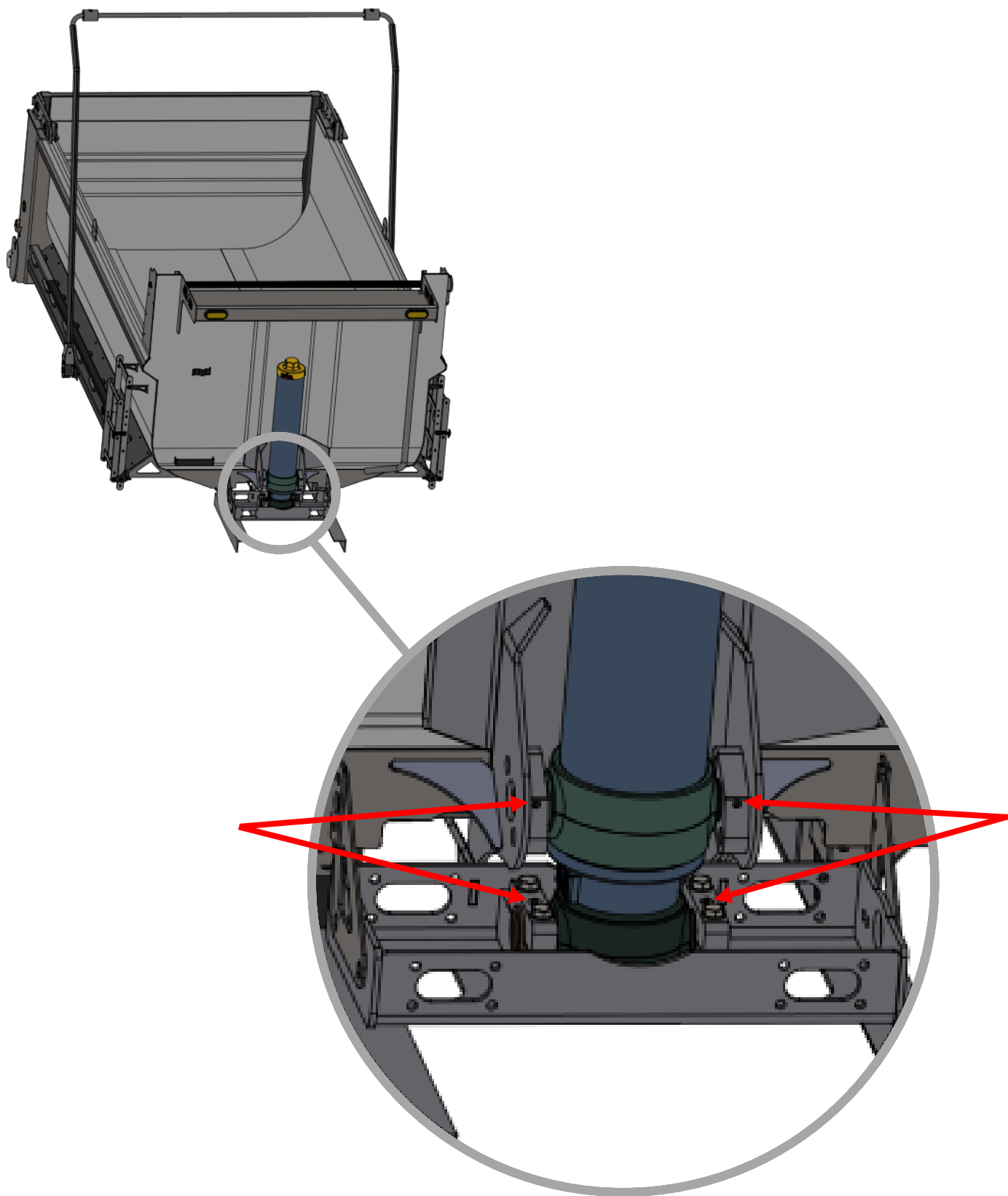

**CAUTION:** ALL grease zerks are to be topped off prior to first use and every month following.

## LUBRICATION AND MAINTENANCE (Cont.)

Lubricate grease zerks in tailgate bottom latch. (1 each side, 2 total). *Locations shown below*

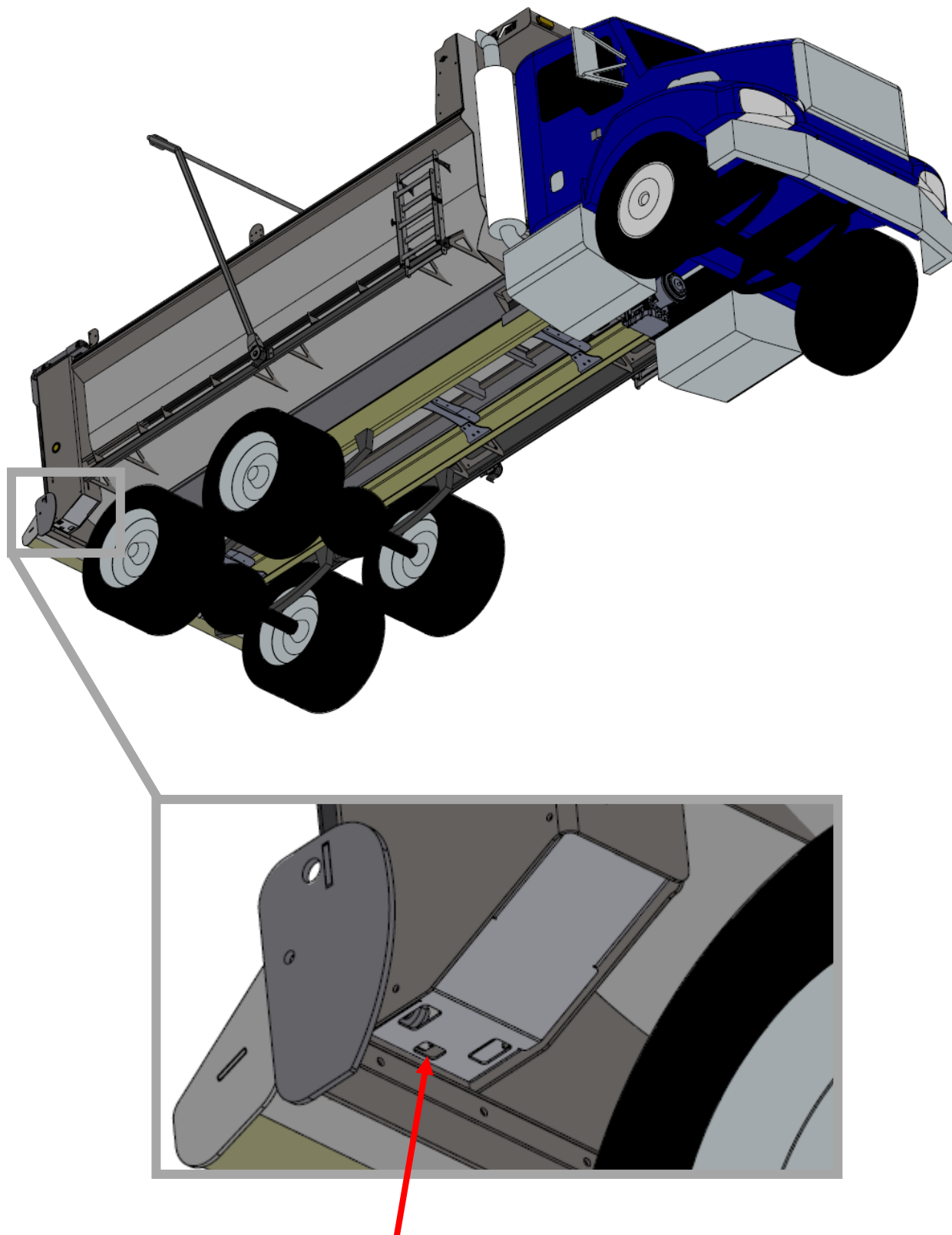

**CAUTION:** ALL grease zerks are to be topped off prior to first use and every month following.

## LOAD KING DUMP BODY LABELS



1



2

<b>! CAUTION</b>
<ul style="list-style-type: none"> <li>· <b>DO NOT</b> operate this equipment until you have been properly trained in its operation.</li> <li>· When vehicle is in transit, the hoist control valve <b>MUST BE</b> kept in neutral and the PTO disengaged.</li> <li>· Tailgate controls <b>MUST BE</b> locked when the vehicle is in transit.</li> <li>· The vehicle <b>MUST BE</b> on level ground before dumping.</li> <li>· <b>DO NOT</b> dump on ground that has been recently excavated or filled without being properly compacted.</li> <li>· Operator <b>MUST REMAIN</b> at the controls during dumping cycle.</li> <li>· Tailgate controls <b>MUST BE</b> released before the front of the body is 2 feet (0.6 m) above the chassis frame.</li> <li>· When operating, <b>DO NOT</b> allow anyone to stand in or move through the area where the hoist operates, or into an area when an upset load might fall.</li> <li>· When the truck is stored or not in use, the body <b>MUST BE</b> in full lowered position, and resting on the chassis or hoist frame. Ignition key <b>SHOULD BE</b> removed to prevent tampering by unauthorized personnel.</li> <li>· Whenever the body is in any elevated or raised position for repairs or adjustments, it <b>MUST BE</b> securely propped or blocked so it can not fall on anyone.</li> <li>· When two props are provided, both props <b>MUST BE USED</b>.</li> </ul>

3

LOAD KING DUMP BODY LABELS (Cont.)



4



5



6

ITEM NO.	PART NUMBER	DESCRIPTION	QTY.
1	DMP00194-5	LARGE LOAD KING LOGO DECAL	3
2	DMP00194-4	GREASE POINT DECAL	6
3	DMP00194-2	CAUTION DECAL	1
4	DMP00194-3	CAUTION - PINCH POINT DECAL	2
5	DMP00194-1	DANGER DECAL	2
6	DMP00195-7	CTOS LOGO DECAL	2

# LOAD KING DUMP BODY LABEL LOCATIONS

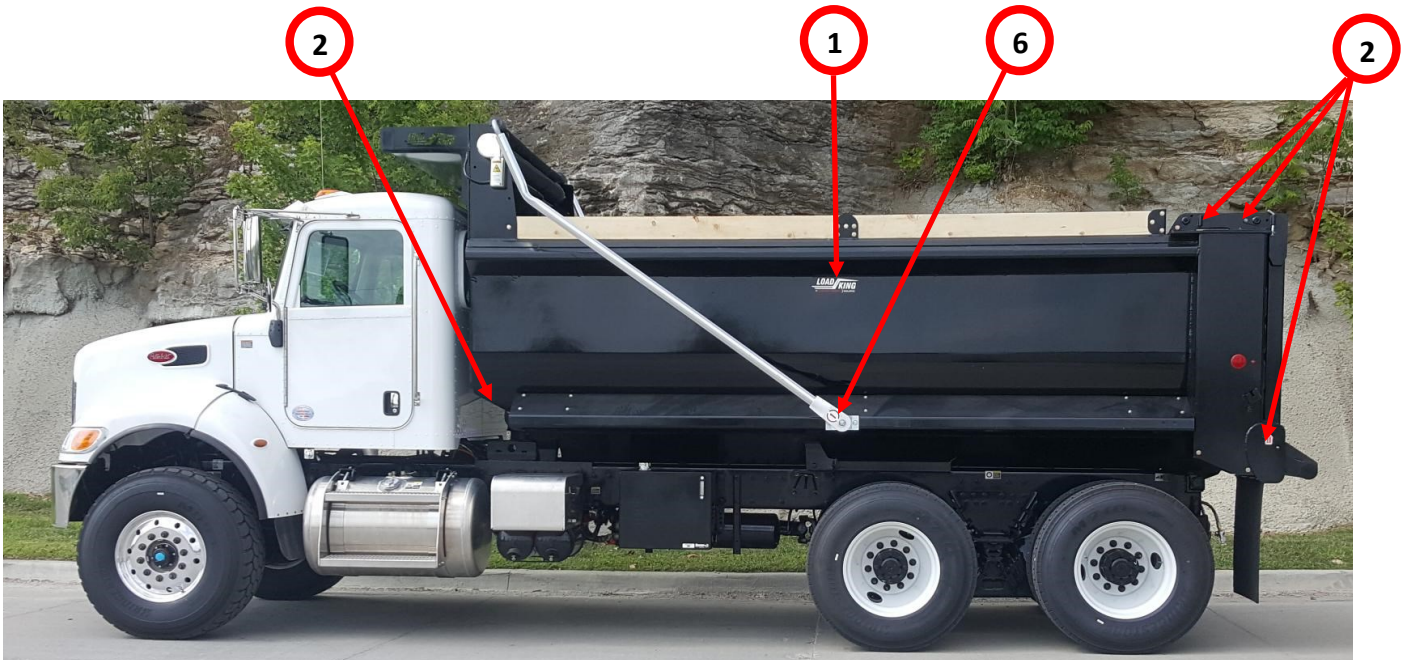

## LOAD KING WARRANTY

*Load King (herein after referred to as the COMPANY) warrants all products manufactured by it and purchased by you to be free from defects in material and manufacture at the time of shipment, for one (1) year from date of delivery. The COMPANY will furnish replacements for such parts as the COMPANY finds to have been defective at the time of delivery or, at the COMPANY's option, will make or authorize repairs to such parts, provided that, upon request, such parts are returned, transportation is prepaid to the factory from which they were shipped.*

*This warranty shall not apply to any Product which has been subjected to misuse, misapplication, overloading, neglect (including but not limited to use of unauthorized parts or attachments), adjustments or repair. Engines, motor, tires, wheels, suspensions, axles, etc. and any accessories furnished with or used in the COMPANY's products, but which are not manufactured by the COMPANY, are not warranted by the COMPANY but are sold only with the express warranty, if any, or the manufacturers thereof. This warranted is limited to the first purchaser/user and is not transferable.*

**THE FOREGOING IS IN LIEU OF ALL OTHER WARRANTIES, WHETHER EXPRESSED OR IMPLIED (INCLUDING, WITHOUT LIMITATIONS, OF MERCHANTABILITY AND FITNESS OF ANY PRODUCT FOR A PARTICULAR PURPOSE), AND OF ANY OTHER OBLIGATION OR LIABILITY ON THE PART OF THE COMPANY. THERE ARE NO WARRANTIES WHICH EXTEND BEYOND THE DESCRIPTION OF THE FACE THEREOF.**

## LIMITATION OF LIABILITY

It is expressly understood and agreed by you that the COMPANY's liability for its products, whether due to breach of warranty, or otherwise is limited to the furnishing of such replacement parts, F.O.B.

factory, and the COMPANY will not be liable for any other injury, loss, damage, or expense, whether direct or consequential, including but not limited to loss of use, income, profit, or production, injury to person or increase in cost of operation, spoilage of or damage to material, arising out of or in connection with the sale, installation, use or inability to use, or the repair or replacement of the COMPANY's products.

All used vehicles and/or bodies are sold in the "AS IS" condition and no expressed or implied warranty is made.

All of COMPANY'S Products are of high quality and are manufactured in conformity with the best commercial practices in the various lines. The COMPANY guarantees all Products manufactured by it to be free from defects in material and manufactured at the time of shipment, for one (1) year from date of delivery. In addition, the COMPANY guarantees the portion of the product to be considered structural for one (1) year from date of manufacture.

While Load King, LLC. designs and manufactures its specific equipment configurations to industry standards, it is ultimate responsibility of the buyer/operator to assure that all loads are properly loaded and distributed.

All loads must comply with the applicable state and federal load limits.

# LOAD KING WARRANTY DATA RECORD

Dump Body Warranty Form Submission		Date	
Date of Delivery			
Model Number			
S/N			
Dealer			
Address			
Customer			
Address			

Record this information at the time that warranty registration form is completed and returned to Load King



Load King

PO Box 427

Elk Point, South Dakota, USA 57025-0427

Toll Free: (888) 264-5522