



LK STINGER 3215
3,200 lbs. Lifting Capacity
Hydraulic/Electric-Hydraulic Service Crane

STINGER 3215



Features: LK STINGER 3215 H/EH

- 3,200 lbs. @ 2 ft. 4 in.
- 10,000 ft-lbs (1.39 ton-m) Crane Rating
- 15 ft. max boom length
- Hydraulic overload protection
- Quick release hook stow
- Square boom design

DIMENSIONS

STINGER 3215

Example Layout Drawing

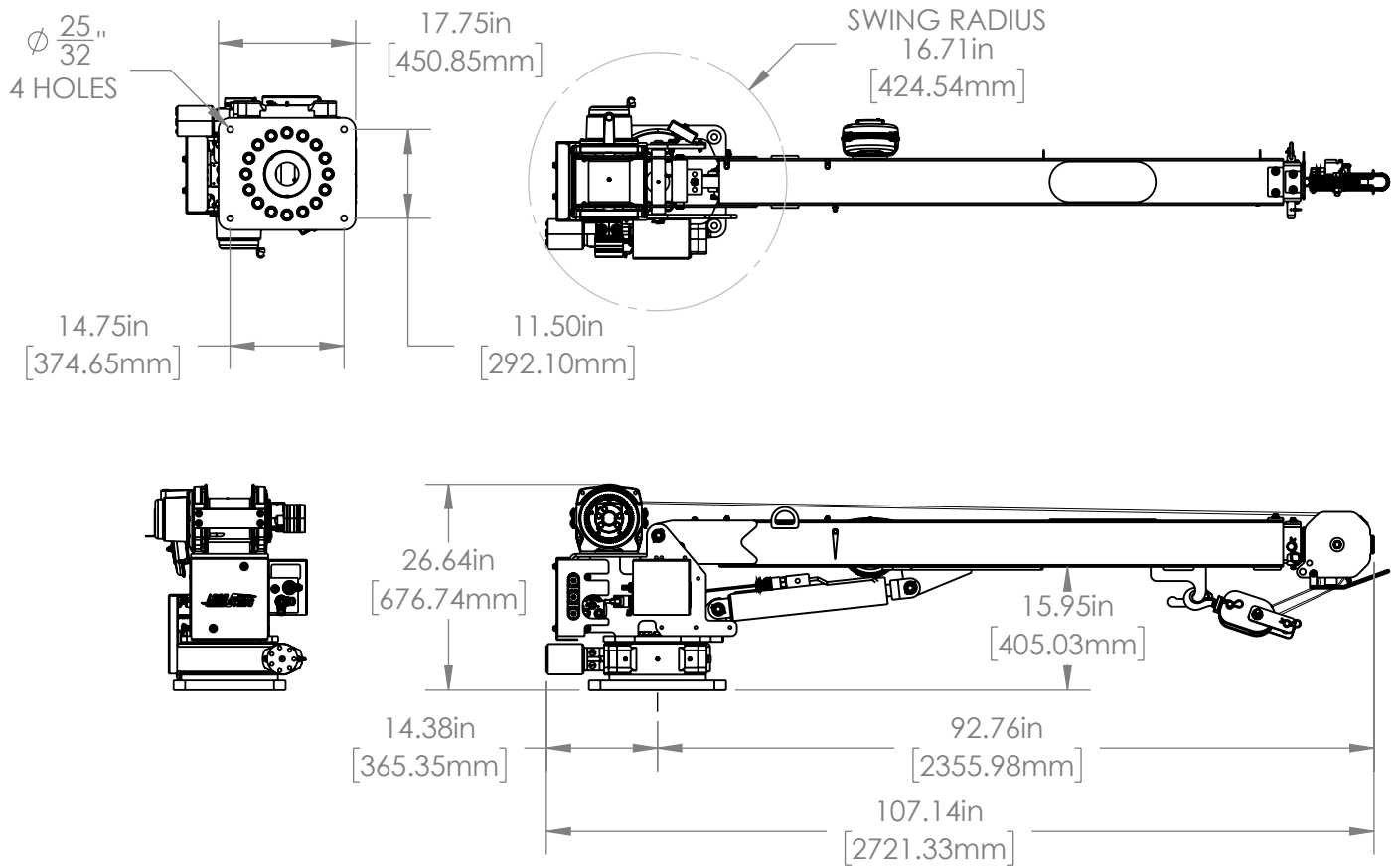

Common Specifications

Minimum Gross Vehicle Weight Rating	8,800 lbs.
Load line	7/32" IWRC x 62 ft. (5.56 mm x 18.9 m)
Storage height	26 5/8" (0.68 m)
Storage length	8' 11" (2.72 m)
Mounting plate	1 1/4" thick (31.8 mm)
Bolt pattern	14.75" x 11.50" (375 mm x 292 mm)
Base plate dimensions	14.50" x 17.75" x 1.25"
RBM per Frame Rail	210,600 lb.-in.
Voltage (Electric/Hydraulic version)	2 x 12 V DC
Alternator (Electric/Hydraulic version)	75 Amp minimum cold-cranking amps
Pump (Hydraulic version)	5 gpm @ 2,100 psi
Paint	White powder coat

RANGE DIAGRAM

Stabilizers Fully Extended

STINGER 3215

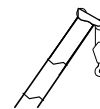

3215

ANSI B30.5

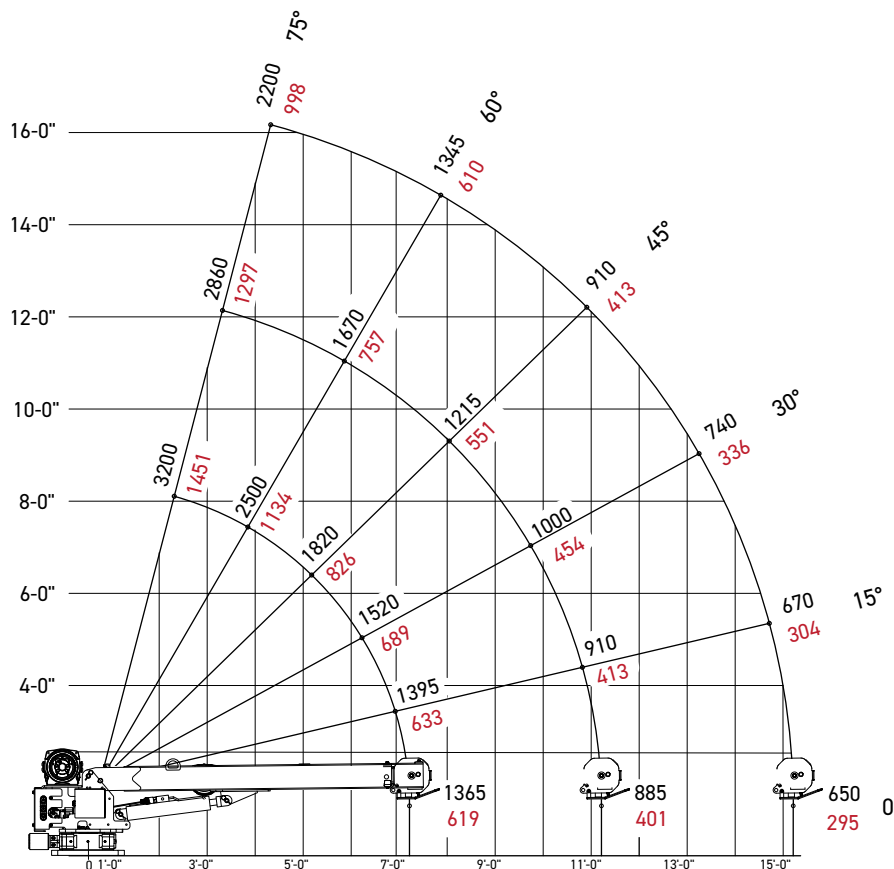

Loads are shown in pounds in black
Kilograms are shown in red

Horizontal reach	15' 0"
Hydraulic extend	48"
Manual extend	48"
Crane weight	625 lbs.
Center of gravity	17.3"
Max capacity at max reach	650 lbs.

Notes to lifting capacity





Lifting capacities do not exceed 85% of tipping load. Weight of hook blocks and slings are part of the load, and are to be deducted from the capacity ratings. Consult operation manual for further details.

Note: Data published herein is intended as a guide only and shall not be construed to warrant applicability for lifting purposes. Crane operation is subject to the computer charts and operation manual both supplied with the crane.





TECHNICAL DESCRIPTION

STINGER 3215

Boom and Rotation

	Three section square boom sections Boom elevation angle range (min/max)	-5° / 75°
	Boom length	15 ft.
	370 degree non-continuous rotation with electromechanical stop	
	Rotation Patented hydraulic motor driven hourglass worm gear swing drive	
	Quick hook stow	

Operator Controls and Operator Aid

	Winch line pull (1st layer)	3,450 lbs.
	Winch line speed (3rd layer)	20 ft./min
	Rope	62 ft. of 7/32" IWRC
	Single radio remote control with radio elimination cable	
	Hydraulic overload protection system	

Stabilizers

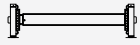

Manual out and down rear stabilizers

10' 10"

FEATURES & BENEFITS

STINGER 3215

Transmitter Controls



FEATURE	BENEFIT
Boom Extension: 15 ft.	3215H: Single Proportional Hydraulic Control 3215EH: Non-Proportional On/Off Control
Square Boom Sections	Self centering booms with less deflection and increased strength
Boom Articulation from -5° to +75°	Large boom angle range
Stabilizer System Design	Manual out, CS out and down with adjustable mounting height.
Hook Block A2B Interlock Control	Easy stow and stops winch function to protect wire rope
Hydraulic planetary winch	Quick line speed and high duty cycle
370° Hydraulic Rotation System	Durable, robust, sealed rotation bearing system
Wireless Remote Control w/ Radio Elimination Cable	Allows crane to work without digital signal when necessary
Powder Coated Corrosion Prevention Finish	Durable, primer and top coat finish for corrosion prevention
Compliant with ANSI B30.5	Meets and exceeds industry standards
Manufactured in Kansas City, MO	Made in the USA
Warranty	5 Year Structural / 2 Year All Components

LOCATIONS

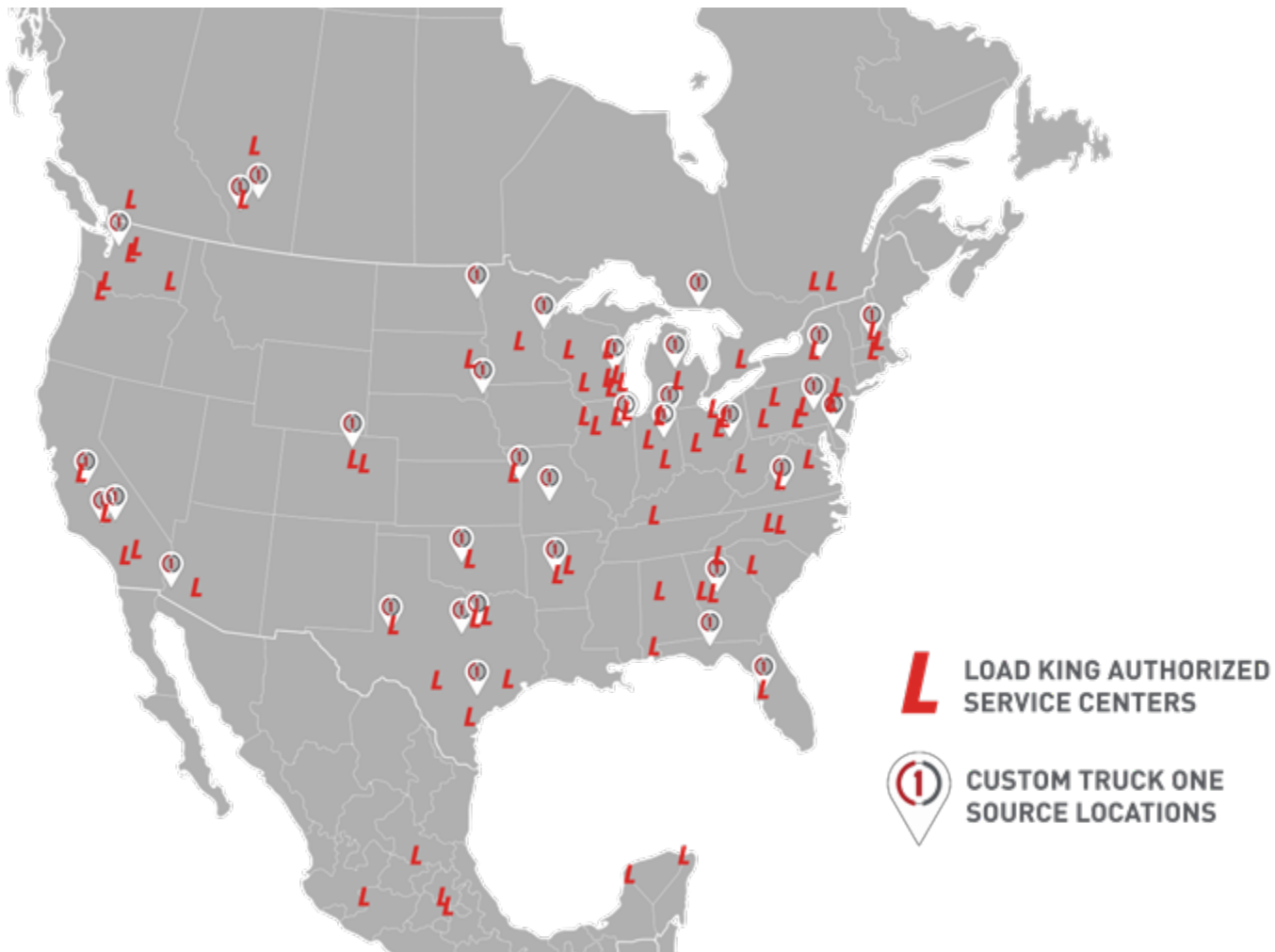

24/7 CALL CENTER
833-281-7911

PARTS QUESTIONS
833-PARTSLK (833-727-8755)
PARTSSUPPORT@LOADKINGMFG.COM

PARTS ORDERS
STORE.LOADKINGMFG.COM

WARRANTY
CRANEWARRANTY@LOADKINGMFG.COM

All our new cranes are backed by an industry-leading 2-year basic and 3-year structural warranty

www.loadkingmfg.com

